

MODEL INFORMATION
CANNED MOTOR PUMP TYPE CAM

HERMETIC *V-Line*

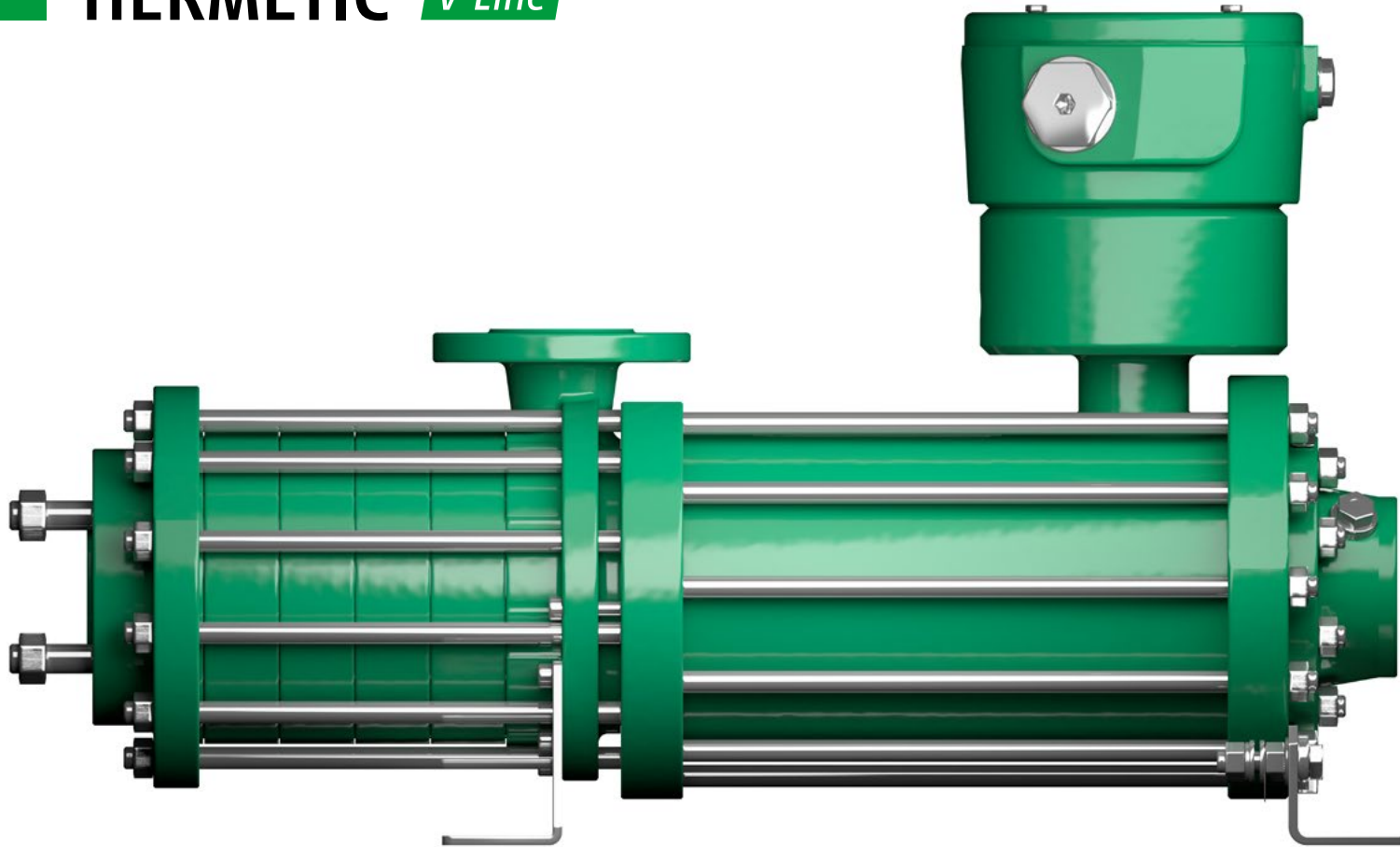

ZART®

simply best balance

Contents

General information	3	Spare parts	14
Characteristic maps	4	Connections	16
3000 rpm 50 Hz / 3600 rpm 60 Hz	4	Collective measurements	17
Advantages	5	Collective measurement drawing	17
Technical data	7	Collective measurement data	18
Modular pump / motor systems	7	Monitoring equipment	20
Materials	8	Options and accessories	21
Pressure and temperature limits	9	Contact	22
Canned motors	10		
Forces and torques	11		
Documentation and tests	13		

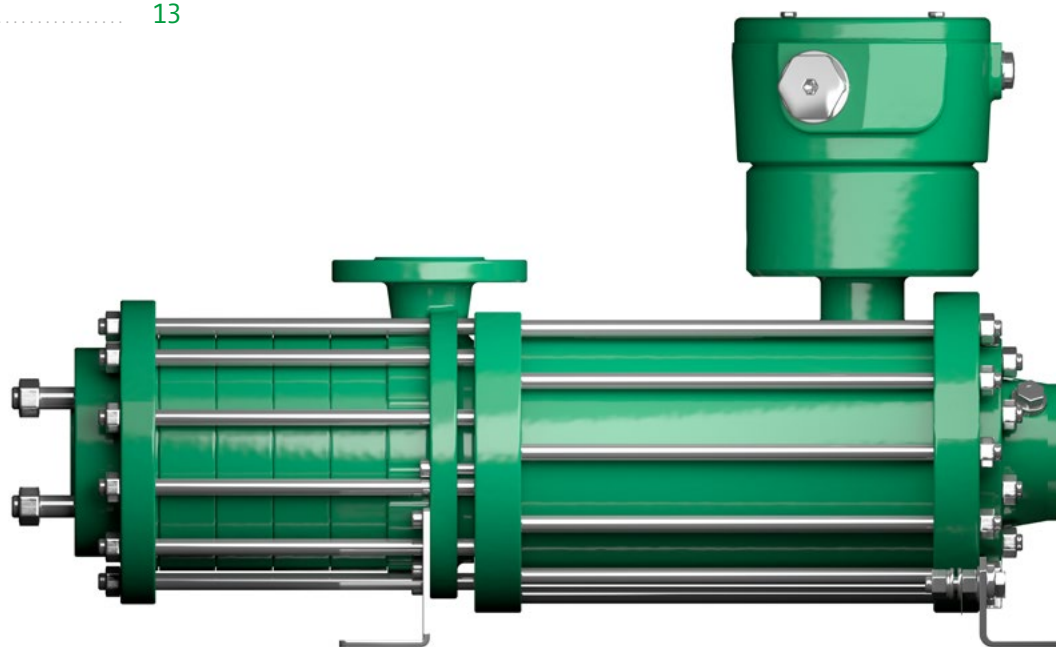

Contents

General information
Characteristic maps
Advantages
Technical data
Documentation and tests
Spare parts
Connections
Collective measurements
Monitoring equipment
Options and accessories
Contact

Information

Operational areas / applications

For the safe transport of aggressive, toxic, hot, explosive, valuable and flammable fluids and liquefied gases.

Model /design

Horizontal, sealless section-type pumps with completely closed canned motor, with radial impellers, multi-stage, single-flow.

Canned motor pump type CAM

This pump is suitable for conveying liquids close to steam pressure and also for standard applications.

Drive

The rotor lining, one of our core competences, is manufactured using the compact extrusion method and as a nickel-base alloy, it is an essential component of the highly efficient canned motor. The pressure-resistant enclosed version of our canned motor complies with explosion protection according to Directive 2014 / 34 / EU. The canned motor filled with liquid accelerates to the operating speed in seconds. It is wear-free and maintenance-free during continuous operation due to the hydrodynamic sleeve bearings. The canned motor with low noise and vibration and offers double security to prevent leaks.

Operating data

Frequency:	50 Hz	60 Hz
Pump capacity [Q]:	1.0 to 36 m ³ /h	1.0 to 40 m ³ /h
Pumping head [H]:	up to 200 m	up to 295 m
Output power [P2]:	max. 41 kW	max. 48 kW
Conveyed material temperature [t]:	-40 °C to +120 °C	-40 °C to +120 °C
Operating pressure:	up to 40 bar	up to 40 bar

(Extended rating scheme available on request)

Pump and hydraulic denomination

CAM 2 / 5 N 14L-2

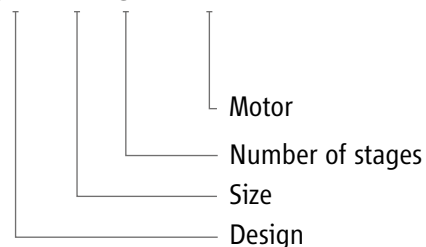

Contents

General information

Characteristic maps

Advantages

Technical data

Documentation and tests

Spare parts

Connections

Collective measurements

Monitoring equipment

Options and accessories

Contact



3000 rpm 50 Hz / 3600 rpm 60 Hz

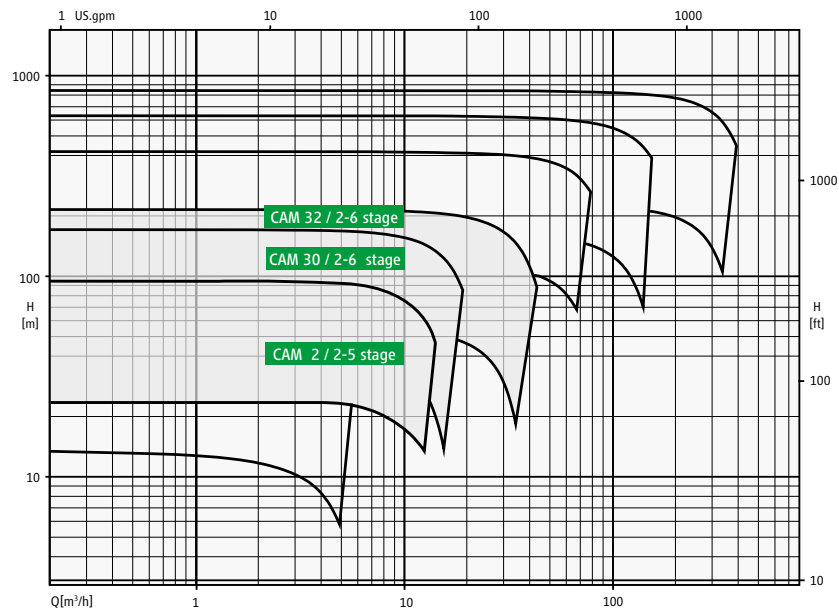

Characteristic map 3000 rpm 50 Hz

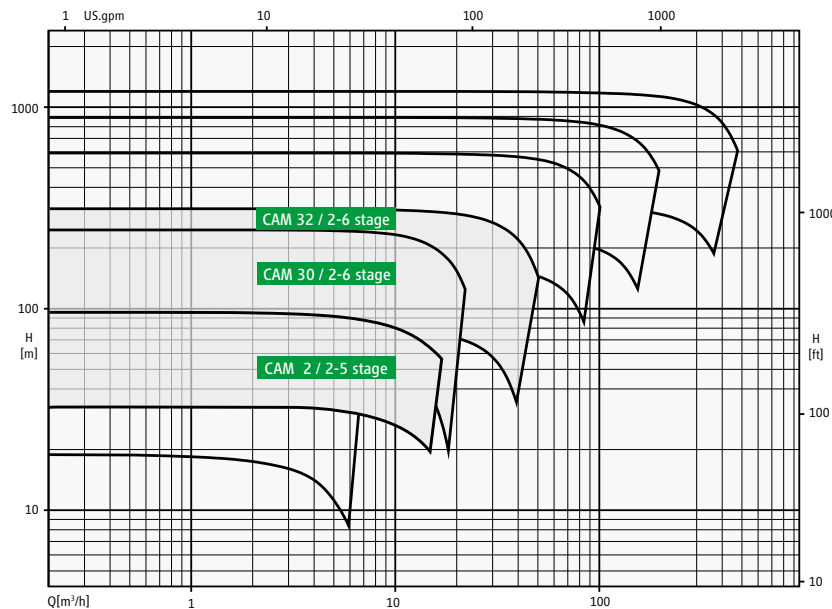

Characteristic map 3600 rpm 60 Hz

Contents

General information

Characteristic maps

Advantages

Technical data

Documentation and tests

Spare parts

Connections

Collective measurements

Monitoring equipment

Options and accessories

Contact



Advantages of the canned motor pump

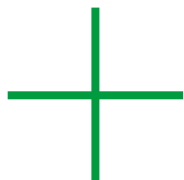

Best Available Pump Technology according to IPCC / TA-LUFT

Leakage-free, long-lasting operation: protection of personnel and environment

No shaft seals

Low space requirement

High level of reliability

Low expenditure for repairs / spare parts

Simple assembly and installation

Long service life of pump and motor

Low life cycle costs

Very smooth running

Contents

General information

Characteristic maps

Advantages

Technical data

Documentation
and tests

Spare parts

Connections

Collective measurements

Monitoring equipment

Options and accessories

Contact



Advantages of the canned motor pump

100 % tightness by two safety casings

Corrosion-resistant rotor lining

Explosion-proof motor (2014/34/EU), vacuum-dried N₂-inertised

Thermal motor protection to prevent overload

High level of functional safety by self-venting

Without shaft seal / sealing system

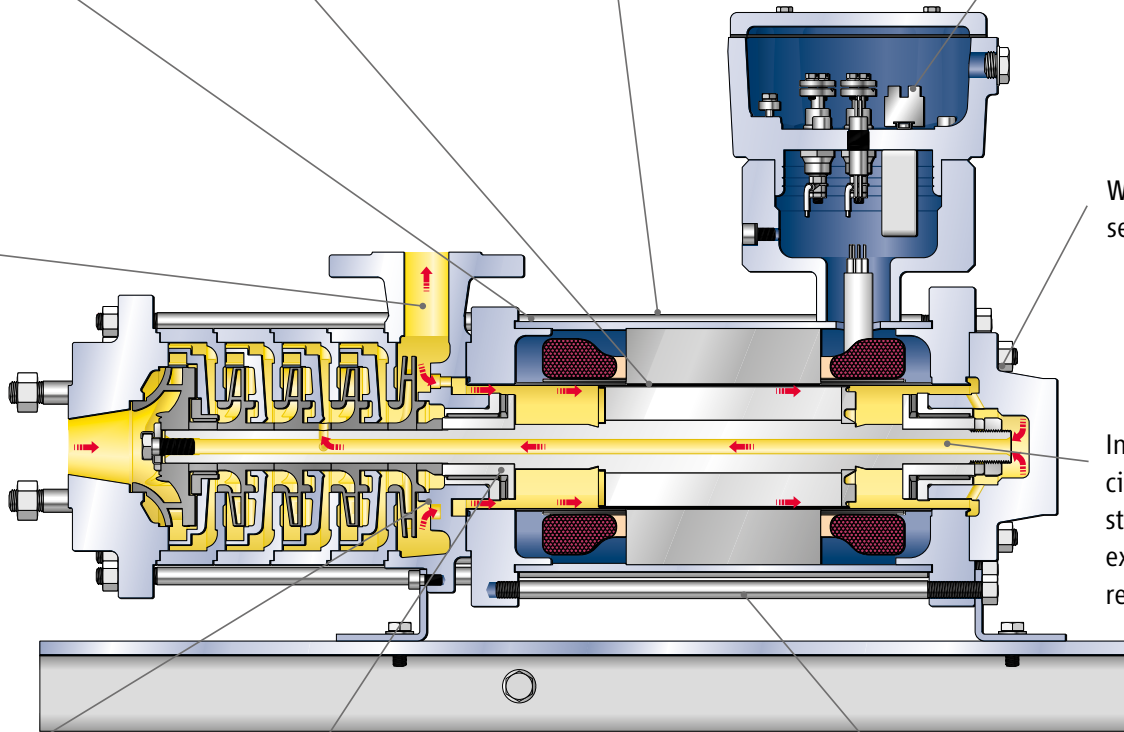

Internal partial flow circulation (also for high steam pressures), no external return line required

Contactless operation by hydrodynamic axial thrust balancing (ZART®)

Wear-resistant and smooth running slide bearing (no roller bearings subject to wear)

No coupling (no alignment of pumps / motor shaft required)

- Contents
- General information
- Characteristic maps
- Advantages
- Technical data**
- Documentation and tests
- Spare parts
- Connections
- Collective measurements
- Monitoring equipment
- Options and accessories
- Contact



Modular pump / motor systems

Hydraulics	Number of stages	Motor output power [P2 at 50 Hz / 60 Hz] max.					
		N14L-2	N24N-2	N34L-2	N34XL-2	N54XL-2	N64XL-2
		2.5 kW / 3.0 kW	6.0 kW / 7.2 kW	8.0 kW / 10.5 kW	14.8 kW / 17.2 kW	24.0 kW / 27.0 kW	41.0 kW / 48.0 kW
CAM 2	2						
	3						
	4						
	5						
CAM 30	2						
	3						
	4						
	5						
	6						
CAM 32	2						
	3						
	4						
	5						
	6						

Extended rating scheme available on request

- Contents
- General information
- Characteristic maps
- Advantages
- Technical data**
- Documentation and tests
- Spare parts
- Connections
- Collective measurements
- Monitoring equipment
- Options and accessories
- Contact



Materials

VDMA No.	Parts designation	Series CAM 2		Series CAM 30 / 32	
		Material design S1 Pressure rating PN 40	Material design A8 Pressure rating PN 40	Material design S1 Pressure rating PN 40	Material design A8 Pressure rating PN 40
Parts coming into contact with conveying fluid					
101	Pump casing	1.0619+N	1.4571	1.0460 / 1.0570	1.4571
108	Stage casing	1.0460	1.4571	1.0460	1.4571
162	Suction cover	1.0460	1.4571	S 355J2+N	1.4571
171	Diffuser insert	JL 1030	1.4581	JS 1030	1.4408
230	Impellers	JL 1030	1.4581	JS 1030	1.4408
360	Bearing cover	1.0460	1.4571	1.0460	1.4571
400	Gasket	AFM34 / Gylon	AFM34 / Gylon	AFM34 / Gylon	AFM34 / Gylon
412	O-ring	–	–	EPDM / FPM / FPM-FEP	EPDM / FPM / FPM-FEP
472	Slide ring	PTFE / K	PTFE / K	PTFE / K	PTFE / K
529	Bearing sleeve	1.4571 / W5 ⁽¹⁾	1.4571 / W5 ⁽¹⁾	1.4571 / W5 ⁽¹⁾	1.4571 / W5 ⁽¹⁾
545	Bearing bush	1.4571 / SiC30	1.4571 / SiC30	1.4571 / SiC30	1.4571 / SiC30
816	Stator liner	2.4610	2.4610	2.4610	2.4610
819	Motor shaft	1.4021 / 1.4571	1.4571	1.4021	1.4571
Parts that do not come into contact with conveying liquid					
811	Motor casing	C-steel ⁽²⁾	C-steel ⁽²⁾	C-steel ⁽²⁾	C-steel ⁽²⁾
812	Motor casing cover	1.4571	1.4571	1.4571	1.4571

(1) tungsten carbide coating

(2) material number depends on motor size

Contents

General information

Characteristic maps

Advantages

Technical data

Documentation
and tests

Spare parts

Connections

Collective measurements

Monitoring equipment

Options and accessories

Contact



Pressure and temperature limits

Material design S1 and A8

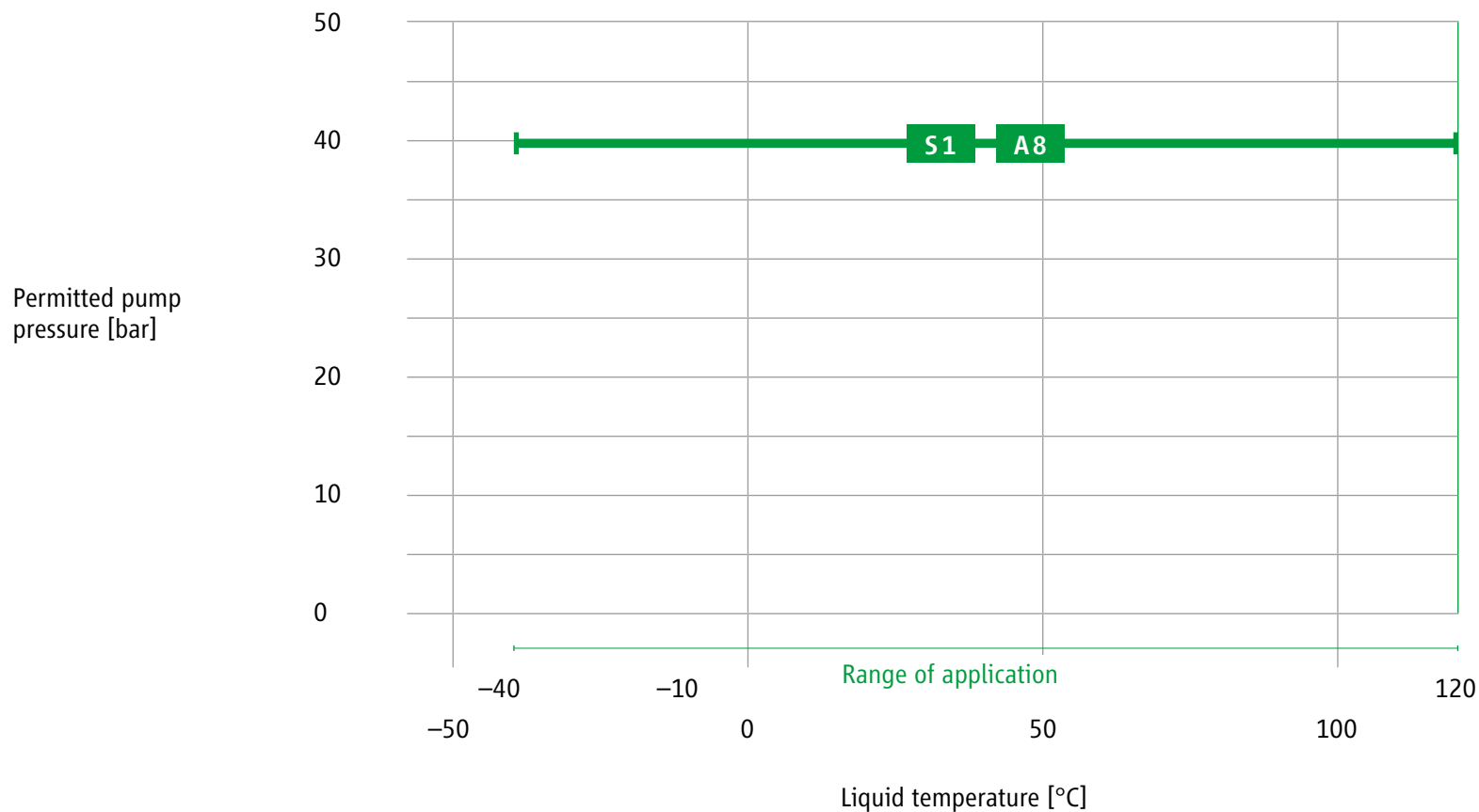

- Contents
- General information
- Characteristic maps
- Advantages
- Technical data**
- Documentation and tests
- Spare parts
- Connections
- Collective measurements
- Monitoring equipment
- Options and accessories
- Contact



Canned motors

Canned motor data

Output power P2:	max. 41 kW (50 Hz) / max. 48 kW (60 Hz)
Voltage (±10%) / frequency / circuit:	400V / 50 Hz / Delta 480V / 60 Hz / Delta 500V / 50 Hz / Delta 600V / 60 Hz / Delta 690V / 50 Hz / star (all canned motors are suitable for inverter operation)
Insulation class:	H-180
Operating mode:	S1 according to EN 60034-1
Protection class:	IP 67 (stator), IP 55 (terminal box)
Motor protection in winding:	Thermistor KL180 (standard), PT100 (option)
Rotation monitoring:	ROMi (integrated as standard from motor size N34L)

Explosion protection according to Directive 2014 / 34 / EU

Incl. EC type-examination certificate

Marking:  II 2 G Ex de IIC T3 to T6

Noise expectancy values

Motors	N14L-2	N24N-2	N34L-2	N34XL-2	N54XL-2	N64XL-2
Output power [P2 at 50 Hz]	2.5 kW	6.0 kW	8.0 kW	14.8 kW	24.0 kW	41.0 kW
max. expected sound pressure level dB(A) at 50 Hz	51	55	57	59	61	64
Output power [P2 at 60 Hz]	3.0 kW	7.2 kW	10.5 kW	17.2 kW	27.0 kW	48.0 kW
max. expected sound pressure level dB(A) at 60 Hz	52	56	58	60	62	64

Contents

General information

Characteristic maps

Advantages

Technical data

Documentation
and tests

Spare parts

Connections

Collective measurements

Monitoring equipment

Options and accessories

Contact



Forces and torques

The pumps are designed so that they can absorb forces and torques according to ISO 5199.

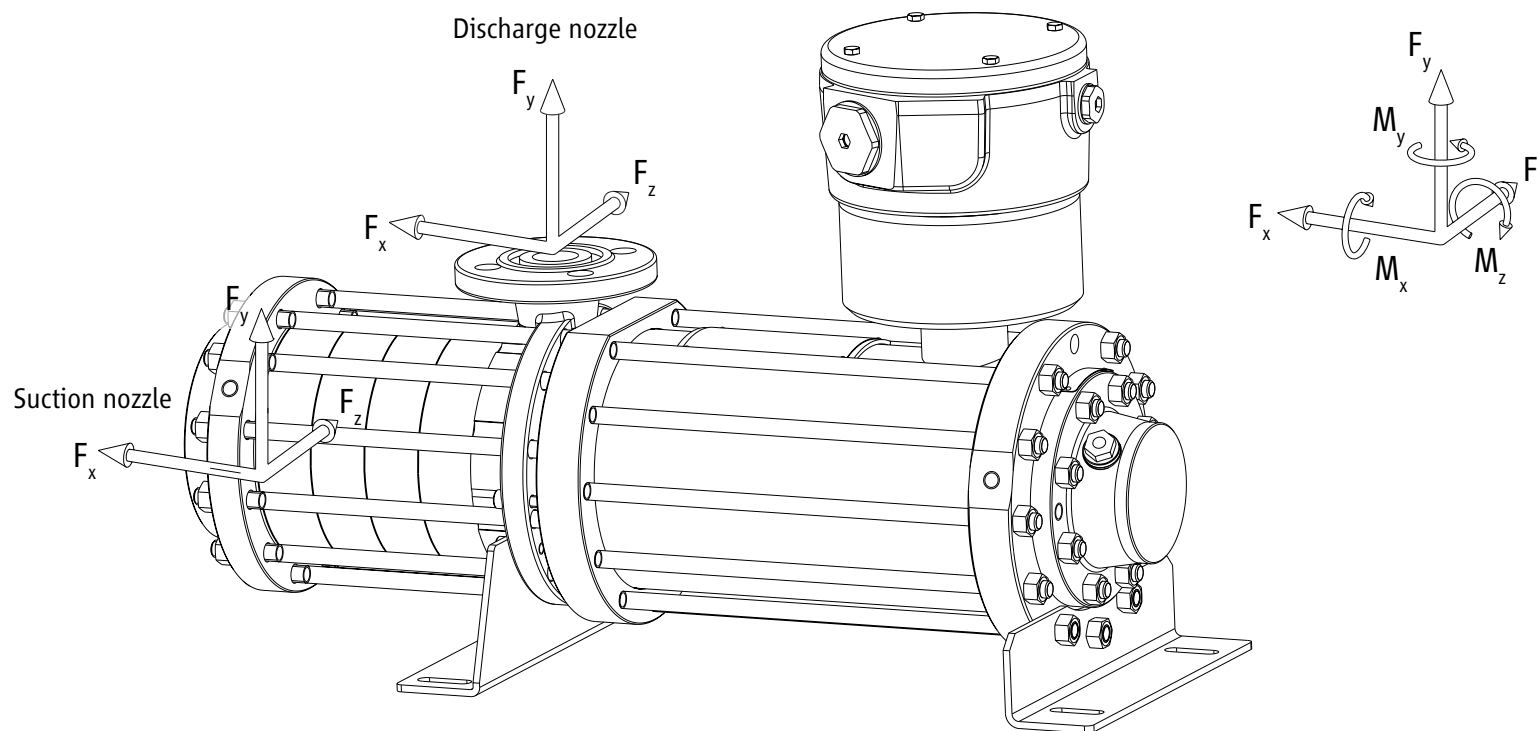

Contents

General information

Characteristic maps

Advantages

Technical data

Documentation and tests

Spare parts

Connections

Collective measurements

Monitoring equipment

Options and accessories

Contact



Permitted forces and torques on the pump nozzles (installation with base plate and firm foundation)

Material design **S1** and material design **A8** up to 120 °C

Sizes	Forces						Torques					
	Suction nozzle in N			Discharge nozzle in N			Suction nozzle in Nm			Discharge nozzle in Nm		
	F _x	F _y	F _z	F _x	F _y	F _z	M _x	M _y	M _z	M _x	M _y	M _z
CAM 2	1200	450	450	400	450	400	700	350	350	200	250	250
CAM 30	900	350	350	500	600	400	360	250	250	200	250	200
CAM 32	1400	650	650	700	850	600	750	450	450	300	400	300

The specifications for the forces and torques only apply for static piping.

The specifications apply for installation with completely encapsulated base plate screwed on a rigid even foundation.

- Contents
- General information
- Characteristic maps
- Advantages
- Technical data**
- Documentation and tests
- Spare parts
- Connections
- Collective measurements
- Monitoring equipment
- Options and accessories
- Contact



Documentation and tests

Documentation according to HERMETIC Standard, consisting of:

Operating manual for the HERMETIC pump

Technical specifications

Sectional and assembly drawings

Dimensional drawing

Cable connection diagram

Pump characteristic curve design

Acceptance report and pump characteristic curve

Electric test report

Slip ring report / gap size report, slide bearing clearancies

Factory certificates according to DIN EN 10 204 / 2.2

EC type-examination certificate PTB 99 ATEX

EU Declaration of Conformity

TÜV certificates

Coating according to HERMETIC Standard

Thickness: 100-200 µm (primer, then 2 coats)

Colour: RAL 7030 (stone grey)

Base plate: powder-coated

Standard tests

Hydrostatic pressure test with 1.5x nominal pressure

Factory certificates according to DIN EN 10 204 / 2.2

Test run according to DIN EN ISO9906, Class 2 B (5 measuring points)

Balancing of the shaft and impellers according to DIN ISO 1940, 6.3 [without report]

Axial thrust measurement

Leak test for the complete pump with N₂ at 6 bar

Optional test

NPSH-test

Contents

General information

Characteristic maps

Advantages

Technical data

**Documentation
and tests**

Spare parts

Connections

Collective measurements

Monitoring equipment

Options and accessories

Contact



Reduced part list

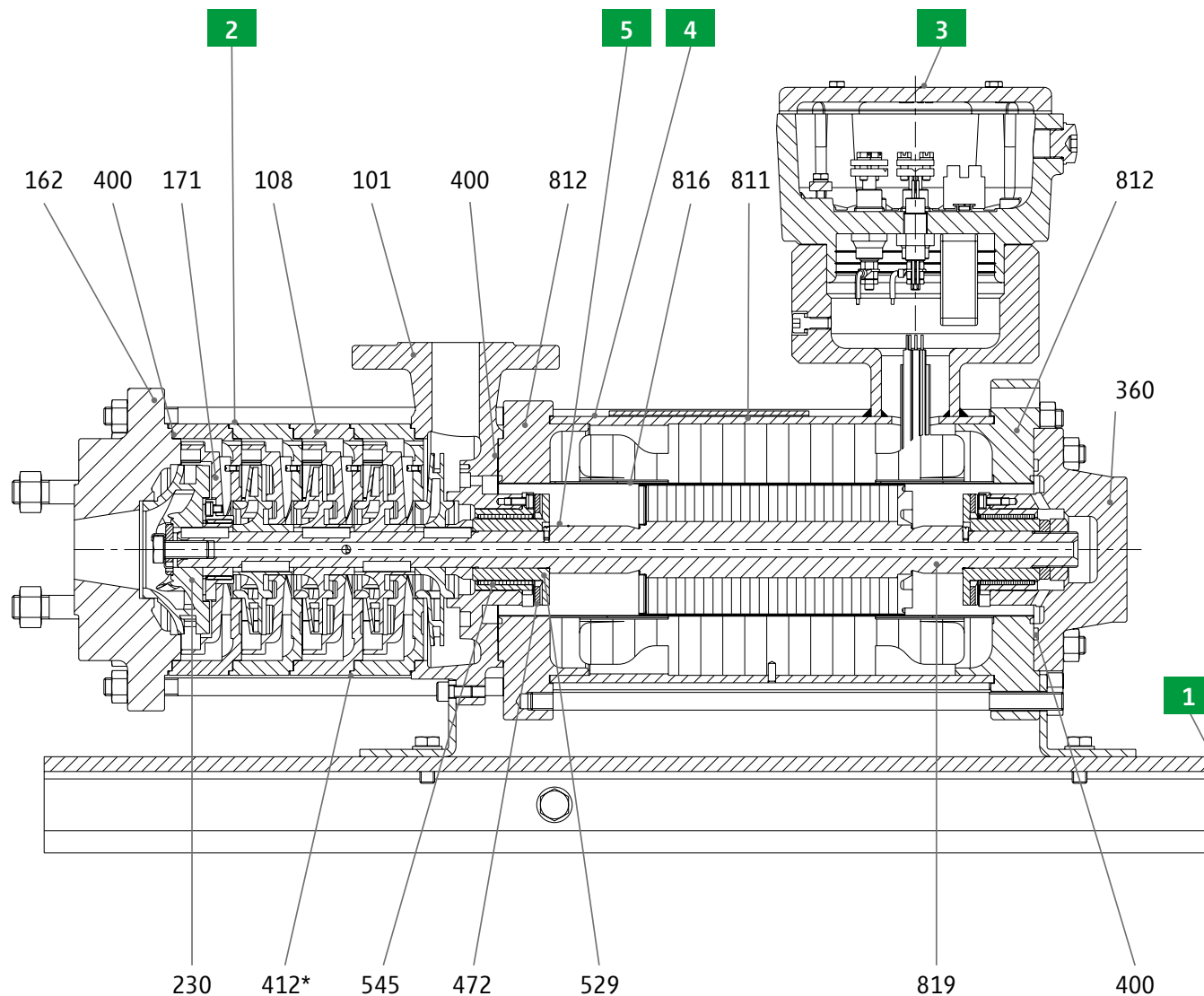

Number	Assembly drawing
1	Base plate
2	Hydraulics
3	Terminal box
4	Motor
5	Motor shaft

* only for CAM 30 / 32

Contents

General information

Characteristic maps

Advantages

Technical data

Documentation and tests

Spare parts

Connections

Collective measurements

Monitoring equipment

Options and accessories

Contact



Reduced part list

VDMA Pos.	Name	Assembly	Assembly drawing
101	Pump casing	Hydraulics	2
108	Stage casing	Hydraulics	2
162	Suction cover	Hydraulics	2
171	Diffuser insert	Hydraulics	2
545	Bearing bush	Hydraulics	2
400	Gasket	Hydraulics	2
400	Gasket	Hydraulics	2
412*	O-ring	Hydraulics	2

400	Spiral gasket	Motor	4
816	Stator liner	Motor	4
812	Motor casing cover, front	Motor	4
812	Motor casing cover	Motor	4
811	Motor casing	Motor	4
360	Bearing cover	Motor	4
545	Bearing bush	Motor	4

Refer to the relevant assembly drawing for the full list of the complete parts. These form part of the standard documentation.

VDMA Pos.	Name	Assembly	Assembly drawing
819	Motor shaft	Motor shaft	5
230	Impellers	Motor shaft	5
529	Bearing sleeve	Motor shaft	5
472	Slide ring	Motor shaft	5

* only for CAM 30 / 32

Recommended spare parts stock

For two-year operation: **none**

For overhaul: **for each pump**

Pos. 400 gasket (depending on number of stages)

2 pcs. Pos. 400 spiral gasket

Pos. 412 O-ring (depending on number of stages)

2 pcs. Pos. 529 bearing sleeve

2 pcs. Pos. 545 bearing bush

2 pcs. Pos. 472 slide ring

Contents

General information

Characteristic maps

Advantages

Technical data

Documentation and tests

Spare parts

Connections

Collective measurements

Monitoring equipment

Options and accessories

Contact



Terminal box connections

Motor rating	Terminal box size	Number and thread for cable gland		Clamping area for cable		Cable inlet connection		Connection cross-section for motor
		Motor	Monitoring	Motor	Monitoring	Motor	Monitoring Multiple feedthrough with 6 wires	
N14L-2	Size 44	1xM25x1.5	1xM20x1.5	Cabel \varnothing 13–18	Cabel \varnothing 6–18	3 x TOS4.16A.690V (M16x1.5)		1.5–6.0 mm ²
N24N-2	Size 44							
N34L-2	Size 54	1xM40x1,5	1xM20x1.5	Cabel \varnothing 17–28	Cabel \varnothing 6–13	3 x PLD 6 (M20x1.5)	1 x (M16x1)	max. 35 mm ²
N34XL-2	Size 54							
N54XL-2	Size 54							
N64XL-2	Size 64	1xM40x1.5	1xM20x1.5	Cabel \varnothing 17–28	Cabel \varnothing 6–13	3 x PLD 8 (M26x1.5)	1 x (M16x1)	16–50 mm ²

Size 44

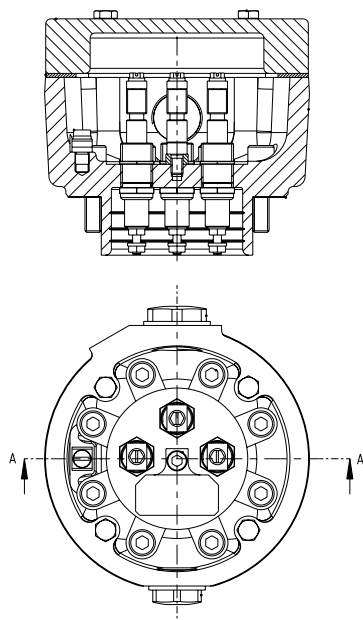

Size 54

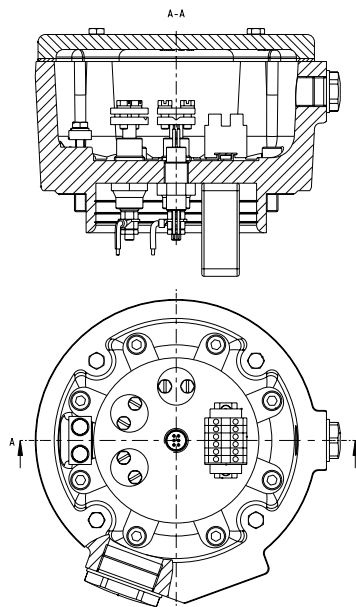

Size 64

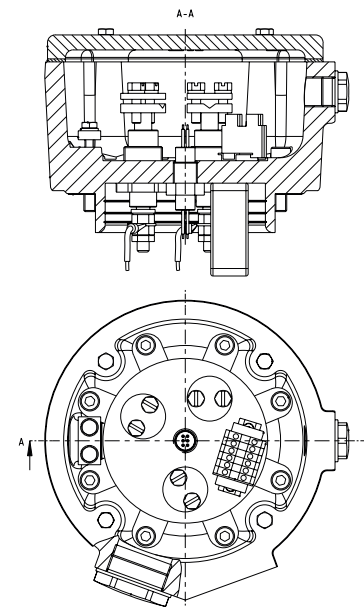

Contents

General information

Characteristic maps

Advantages

Technical data

Documentation and tests

Spare parts

Connections

Collective measurements

Monitoring equipment

Options and accessories

Contact



Collective measurement drawing

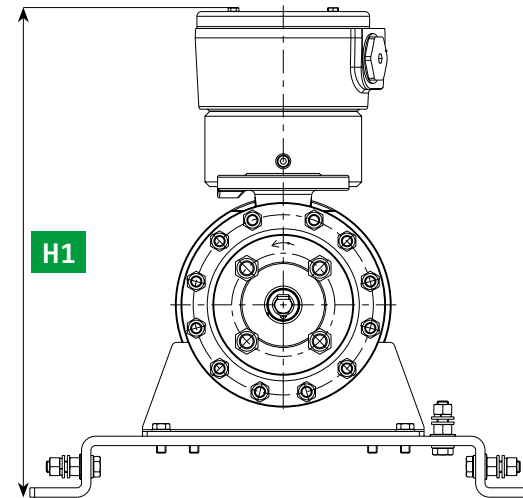
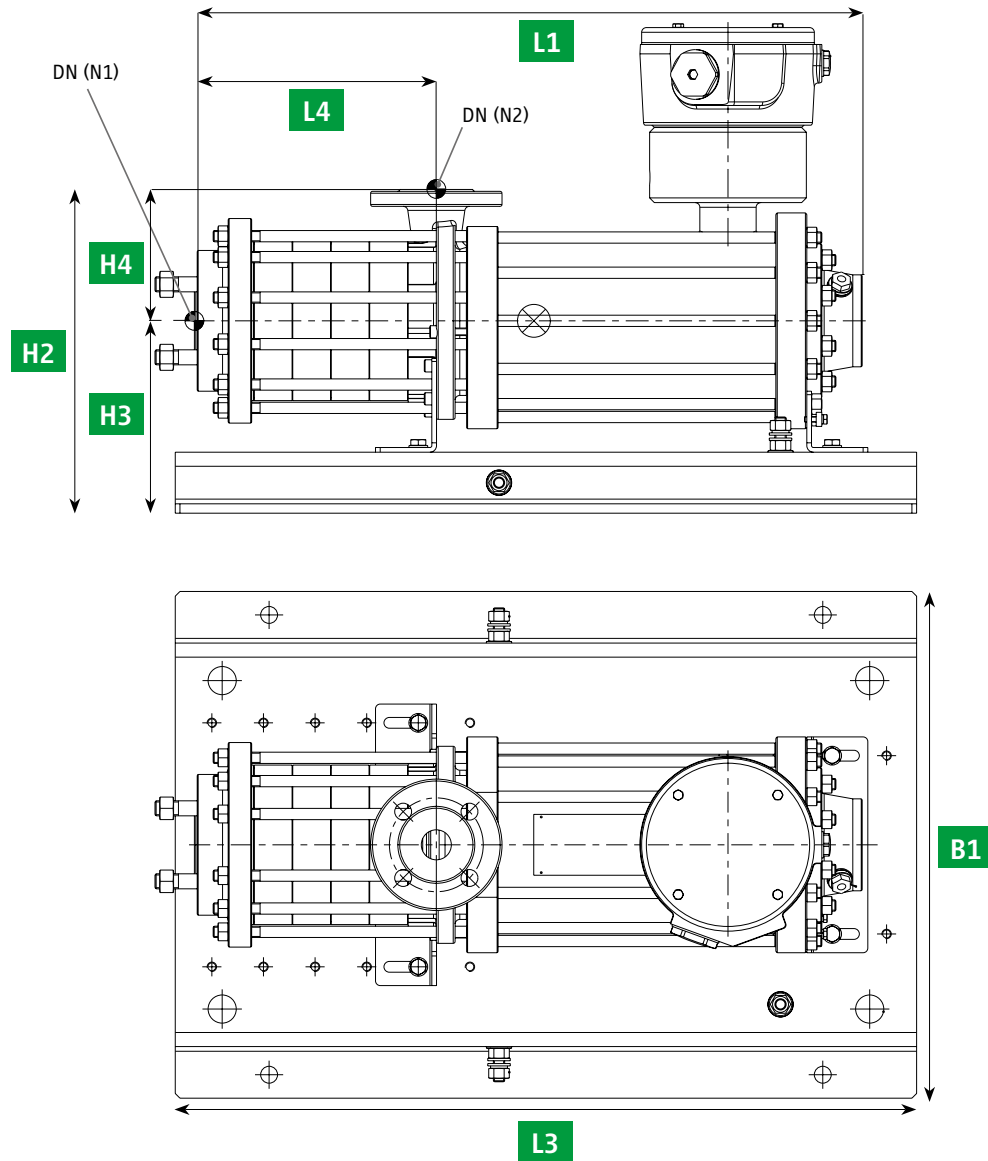

- Contents
- General information
- Characteristic maps
- Advantages
- Technical data
- Documentation and tests
- Spare parts
- Connections
- Collective measurements**
- Monitoring equipment
- Options and accessories
- Contact



Collective measurement data

Hydraulics	Stages	Motor	H1	L1	H2	H3	H4	L4	L3	B1	DN (N1)	DN (N2)	Total approx. weight in kg
CAM 2	2-stage	N14L-2	458	514	330	190	140	135	790	540	40	32	147
		N24N-2	468	520	330	190	140	135	790	540	40	32	158
	3-stage	N14L-2	458	555	330	190	140	176	790	540	40	32	147
		N24N-2	468	561	330	190	140	176	790	540	40	32	158
	4-stage	N14L-2	458	596	330	190	140	217	790	540	40	32	147
		N24N-2	468	602	330	190	140	217	790	540	40	32	158
	5-stage	N14L-2	458	637	330	190	140	258	790	540	40	32	147
		N24N-2	468	643	330	190	140	258	790	540	40	32	158
		N34L-2	522	712	345	205	140	258	790	540	40	32	179
CAM 30	2-stage	N24N-2	578	539	460	260	200	125	790	540	50	25	180
		N34L-2	578	608	460	260	200	125	790	540	50	25	210
		N34XL-2	578	703	460	260	200	125	790	540	50	25	220
	3-stage	N24N-2	578	579	460	260	200	165	790	540	50	25	190
		N34L-2	578	648	460	260	200	165	790	540	50	25	220
		N34XL-2	578	743	460	260	200	165	790	540	50	25	230
	4-stage	N24N-2	578	619	460	260	200	205	790	540	50	25	200
		N34L-2	578	688	460	260	200	205	790	540	50	25	230
		N34XL-2	578	783	460	260	200	205	790	540	50	25	240
	5-stage	N34L-2	578	728	460	260	200	245	790	540	50	25	240
		N34XL-2	578	823	460	260	200	245	790	540	50	25	250
	6-stage	N34XL-2	578	863	460	260	200	285	790	540	50	25	260

Contents

General information

Characteristic maps

Advantages

Technical data

Documentation
and tests

Spare parts

Connections

Collective measurements

Monitoring equipment

Options and accessories

Contact



Collective measurement data

Hydraulics	Stages	Motor	H1	L1	H2	H3	H4	L4	L3	B1	DN (N1)	DN (N2)	Total approx. weight in kg
CAM 32	2-stage	N24N-2	578	562	470	260	210	143	790	540	80	40	200
		N34L-2	578	631	470	260	210	143	790	540	80	40	225
		N34XL-2	578	726	470	260	210	143	790	540	80	40	245
		N54XL-2	578	821	470	260	210	143	790	540	80	40	300
		N64XL-2	578	926	470	260	210	143	790	540	80	40	375
	3-stage	N24N-2	578	612	470	260	210	193	790	540	80	40	215
		N34L-2	578	681	470	260	210	193	790	540	80	40	235
		N34XL-2	578	776	470	260	210	193	790	540	80	40	260
		N54XL-2	578	871	470	260	210	193	790	540	80	40	310
		N64XL-2	578	976	470	260	210	193	790	540	80	40	390
	4-stage	N24N-2	578	662	470	260	210	243	790	540	80	40	225
		N34L-2	578	731	470	260	210	243	790	540	80	40	250
		N34XL-2	578	826	470	260	210	243	790	540	80	40	270
		N54XL-2	578	921	470	260	210	243	790	540	80	40	325
		N64XL-2	578	1026	470	260	210	243	790	540	80	40	400
	5-stage	N34XL-2	578	876	470	260	210	293	790	540	80	40	285
		N54XL-2	578	971	470	260	210	293	790	540	80	40	335
		N64XL-2	578	1076	470	260	210	293	790	540	80	40	415
	6-stage	N34XL-2	578	926	470	260	210	343	790	540	80	40	300
		N54XL-2	578	1021	470	260	210	343	790	540	80	40	340
N64XL-2		578	1126	470	260	210	343	790	540	80	40	340	

Contents

General information

Characteristic maps

Advantages

Technical data

Documentation and tests

Spare parts

Connections

Collective measurements

Monitoring equipment

Options and accessories

Contact



Overview of the safety- and function-related monitoring equipment

Level monitoring of the pumped liquid for detecting and avoiding dry running



Level monitoring by / with:

- KSR magnetic float switch [LS]
- Vibration limit switch [LS]
- Optoelectronic liquid level limit transducer [LS]

Temperature monitoring for detecting and avoiding inadmissible high temperatures in the pump and the motor



Temperature monitoring by / with:

- Resistance thermometer PT100 [TI]
(not possible for motor sizes N14L-2 and N24N-2)
- Thermistor KL180 [TS]

Rotor position monitoring for detecting and avoiding axial wear



Rotor position monitoring by / with:

- ACS [GI]

Rotation monitoring for detecting and avoiding incorrect phase sequence



Rotation monitoring by / with:

- ROMi [GS]
(not possible for motor sizes N14L-2 and N24N-2)

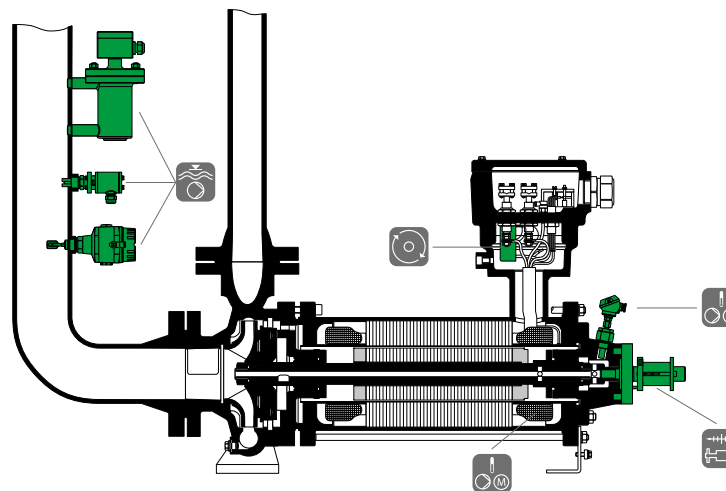

Example shown

Contents

General information

Characteristic maps

Advantages

Technical data

Documentation and tests

Spare parts

Connections

Collective measurements

Monitoring equipment

Options and accessories

Contact



Options and accessories

Options, without delivery time extension

Gaskets	Gylon 3501 E
Flange designs	<ul style="list-style-type: none"> ■ Type D (with groove) ■ Drilled according to ANSI 150 lbs / 300 lbs
Drains	Drilled, closed with plugs

Options, with delivery time extension

Voltages	500V / 50 Hz, 600V / 60 Hz
Winding protection	Resistance thermometer PT100 instead of KL180 (switching amplifier on request)
Drain with flange	Arrangement right / left (EN1092-1, type B1 / type D, ANSI 150 / 300 lbs RF)
Inducer (not for series CAM 2)	
Axial Control System ACS	

Accessory

Level monitoring	<ul style="list-style-type: none"> ■ KSR magnetic float switch ■ Vibration limit switch ■ Optoelectronic liquid level limit transducer
Temperature monitoring	<ul style="list-style-type: none"> ■ Resistance thermometer PT100
Levelling disc with adjusting screws, Isoloc	
Qmax-orifice	
Rotation monitoring, external	ROMe (for motors N14 L and N24 N)
Base plate	is always a component of delivery
Connection for PT100	is always a component of delivery

- Contents
- General information
- Characteristic maps
- Advantages
- Technical data
- Documentation and tests
- Spare parts
- Connections
- Collective measurements
- Monitoring equipment
- Options and accessories**
- Contact



MODEL INFORMATION

Contact

sales-support@hermetic-pumpen.com

www.hermetic-pumpen.com

Contents

General information

Characteristic maps

Advantages

Technical data

Documentation
and tests

Spare parts

Connections

Collective measurements

Monitoring equipment

Options and accessories

Contact